

Schottky Barrier Diode

Features

- Low Forward Voltage Drop
- Extremely Small SOD-323 Package
- Surface Device Type Mounting
- RoHS Compliant
- Green EMC
- Band Indicates Cathode
- Marking: JU4

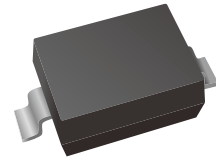

Applications

- Low voltage rectification
- Reverse polarity protection
- Low power consumption applications

Absolute Maximum Ratings (TA=25°C unless otherwise specified)

Symbol	Parameter	Value	Units
V_{RRM}	Maximum repetitive reverse voltage	40	V
V_R	Maximum DC blocking reverse voltage	40	V
$I_{F(AV)}$	Average Forward Current	1	A
I_{FSM}	Peak Forward Surge Current (At 8.3ms single half sine-wave)	20	A
T_J	Operating Junction Temperature	-50 to +125	°C
T_{STG}	Storage Temperature Range	-50 to +150	°C

These ratings are limiting values above which the serviceability of the diode may be impaired.

Electrical Characteristics (TA=25°C unless otherwise specified)

Parameter	Symbol	Min.	Typ.	Max.	Unit
Breakdown Voltage at $I_R=0.1mA$	V_{BR}	40			V
Reverse Leakage Current at $V_R=40V$	I_R			80	μA
Forward Voltage at $I_F=1A$	V_F		0.37	0.42	V
Forward Voltage at $I_F=2A$	V_F			0.50	V
Junction Capacitance $V_R = 0V, f = 1MHz$	C_J		340	400	pF

Characteristic Curves

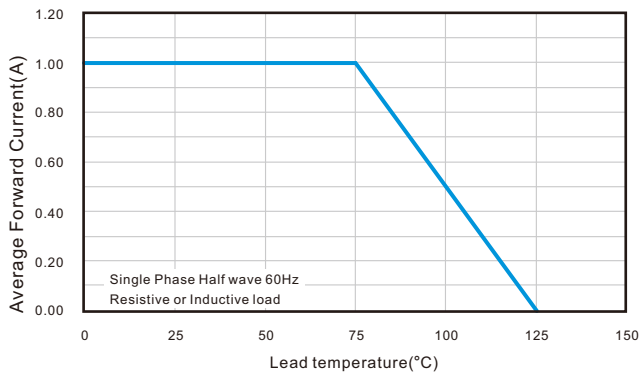
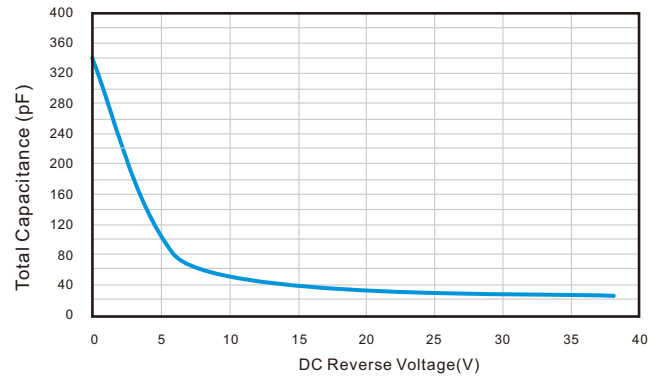
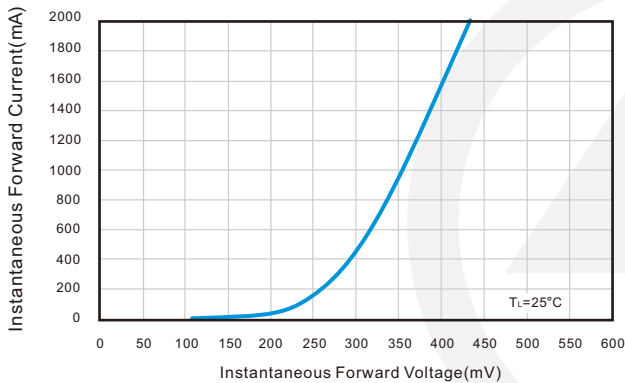
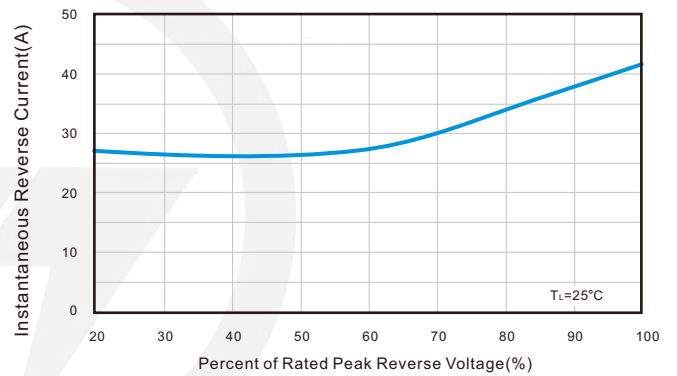
Fig 1 Typical Forward Current Derating Curve

Fig 2 Total Capacitance vs. Reverse Voltage

Fig 3 Typical Instantaneous Forward Characteristics

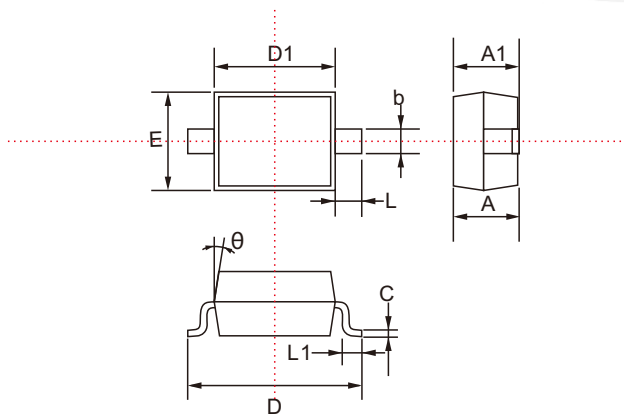
Fig 4 Typical Reverse Characteristics

SOD-323 Package Outline

Unit: mm



SYMBOL	DIMENSIONS	
	MIN.	MAX.
A1	0.800	1.100
A	0.800	0.900
b	0.250	0.400
C	0.080	0.177
D	2.300	2.800
D1	1.400	1.800
E	1.150	1.400
L1	0.100	0.400
L	0.475 TYP.	
θ	8°	

SOD-323 Suggested Pad Layout

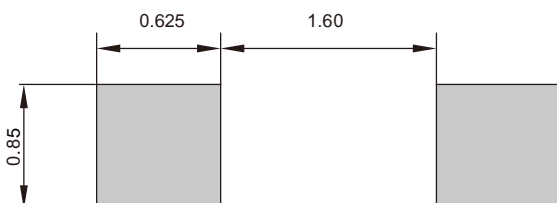

Note:

1. Controlling dimension: in millimeters.
2. General tolerance: $\pm 0.05\text{mm}$
3. The pad layout is for reference purpose only.

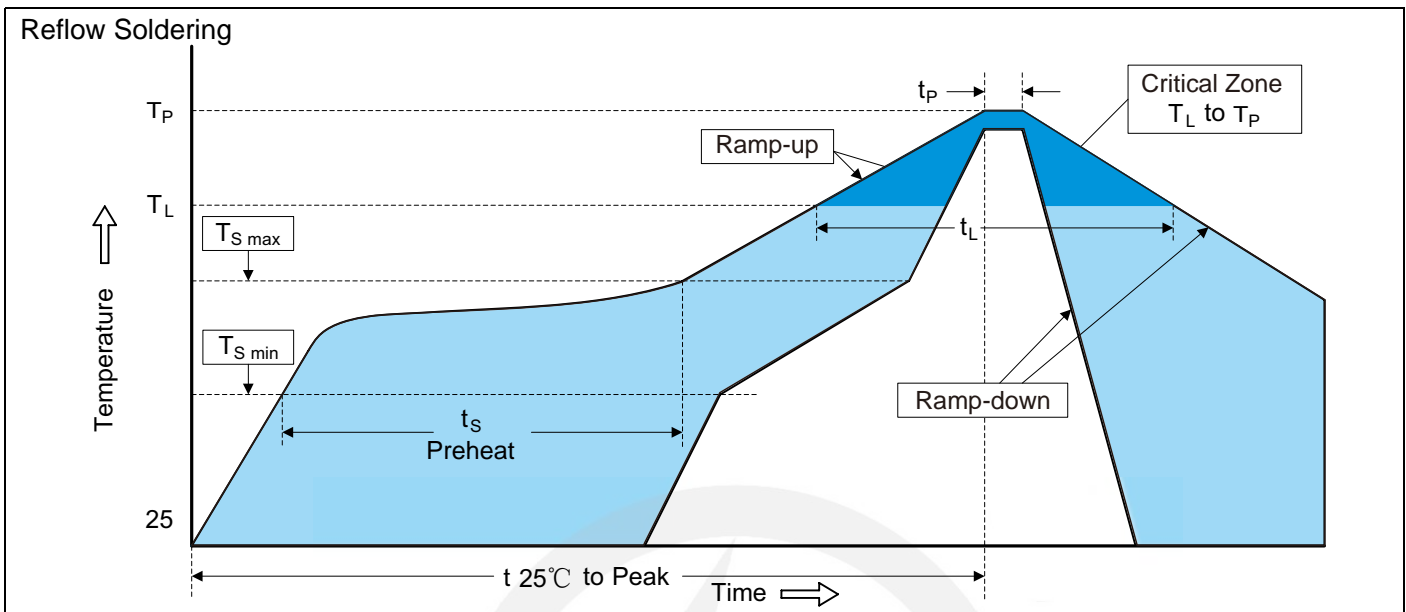
Recommended Soldering Conditions

Recommended Conditions

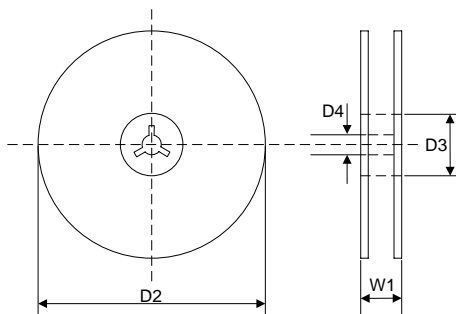
Profile Feature	Pb-Free Assembly
Average ramp-up rate (T_L to T_P)	3°C/second max.
Preheat -Temperature Min ($T_{S\ min}$) -Temperature Max ($T_{S\ max}$) -Time (min to max) (t_s)	150°C 200°C 60-180 seconds
$T_{S\ max}$ to T_L -Ramp-up Rate	3°C/second max.
Time maintained above: -Temperature (T_L) -Time (t_L)	217°C 60-150 seconds
Peak Temperature (T_P)	260°C
Time within 5°C of actual Peak Temperature (t_P)	20-40 seconds
Ramp-down Rate	6°C/second max.
Time 25°C to Peak Temperature	8 minutes max.

7" Reel

D2	$\Phi 178.0 \pm 2.0$
----	----------------------

D3	$\Phi 50.0 \text{ Min.}$
----	--------------------------

D4	$\Phi 13.0 \pm 0.5$
----	---------------------

W1	16.0 ± 2.0
----	----------------

Quantity: 3000PCS